

Clamping equipment MC complete with wrench , work stop, rigid slide way ( floating slide-way at request for raw workpiece), pair of positioning keys, pair of CLAK parallels, cover for protection of the screw, cardboard box.

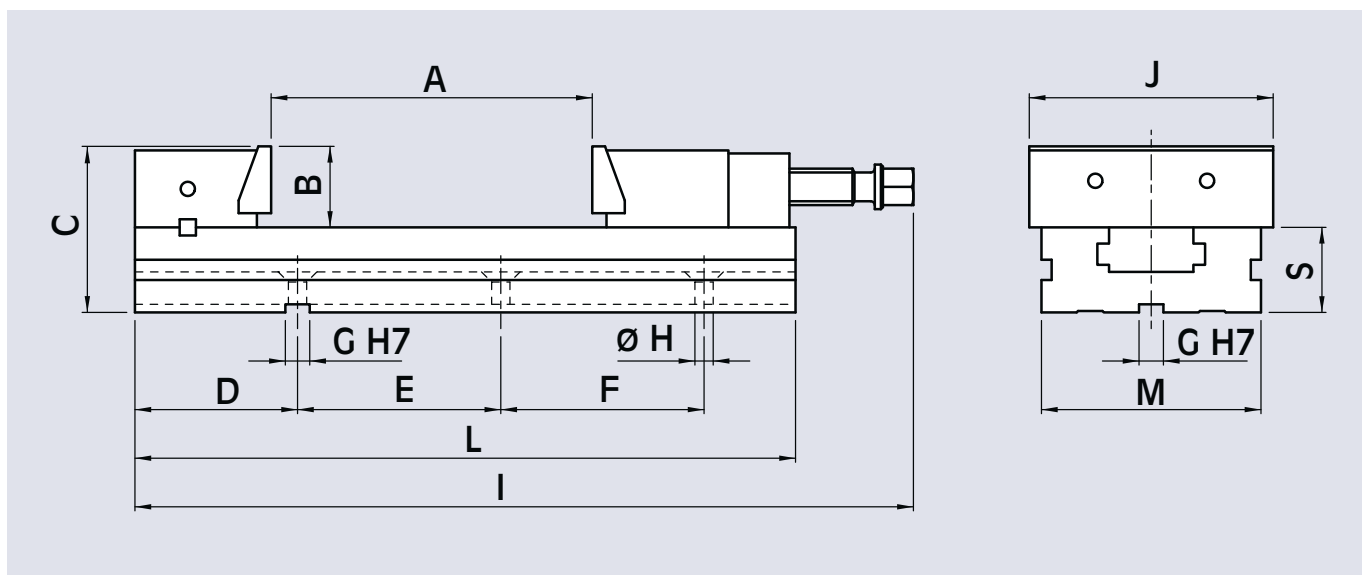

Cod.	type	A mm	B mm	C mm	D mm	E mm	F mm	G mm	H mm	I mm	J mm	L mm	M mm	O mm	S mm	weight kg
77 58 06 01	MC 150 x 200	200	50	102	120	200	-	18	12,5	482	150	415	128	85	52	25,5
77 58 06 02	MC 150 x 250	250	50	102	120	100	100	18	12,5	532	150	465	128	85	52	27,5
77 58 06 03	MC 150 x 300	300	50	102	120	100	100	18	12,5	587	150	520	128	85	52	30,4
77 58 07 01	MC 200 x 300	300	70	136	150	150	150	18	12,5	656	200	570	168	109	66	66
77 58 07 02	MC 200 x 400	400	70	136	150	200	200	18	12,5	756	200	670	168	109	66	68